

FEATURE

- NPN silicon epitaxial planar transistor for switching and Amplifier applications
- As complementary type, the PNP transistor 2N3906 is Recommended
- This transistor is also available in the SOT-23 case with the type designation MMBT3904

TRANSISTOR (NPN)

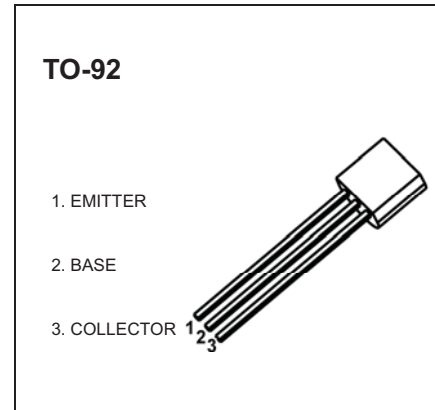

MARKING

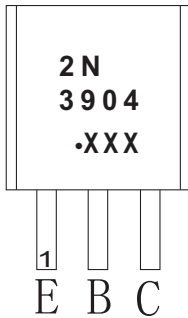

2N3904=Device code

Solid dot=Green molding compound device, if none, the normal device

XXX=Code

Equivalent Circuit

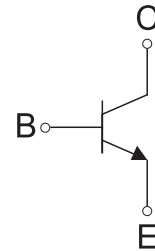

ORDERING INFORMATION

Part Number	Package	Packing Method	Pack Quantity
2N3904	TO-92	Bulk	1000pcs/Bag
2N3904-TA	TO-92	Tape	2000pcs/Box

MAXIMUM RATINGS (T_a=25°C unless otherwise noted)

Symbol	Parameter	Value	Unit
V _{CB0}	Collector-Base Voltage	60	V
V _{CEO}	Collector-Emitter Voltage	40	V
V _{EBO}	Emitter-Base Voltage	6	V
I _C	Collector Current -Continuous	0.2	A
P _C	Collector Power Dissipation	0.625	W
T _J	Junction Temperature	150	°C
T _{stg}	Storage Temperature	-55-150	°C

ELECTRICAL CHARACTERISTICS
 $T_a=25^\circ\text{C}$ unless otherwise specified

Parameter	Symbol	Test conditions	Min	Typ	Max	Unit	
Collector-base breakdown voltage	$V_{(BR)CBO}$	$I_C=10\mu\text{A}, I_E=0$	60			V	
Collector-emitter breakdown voltage	$V_{(BR)CEO}$	$I_C=1\text{mA}, I_B=0$	40			V	
Emitter-base breakdown voltage	$V_{(BR)EBO}$	$I_E=10\mu\text{A}, I_C=0$	6			V	
Collector cut-off current	I_{CBO}	$V_{CB}=60\text{V}, I_E=0$			0.1	μA	
Collector cut-off current	I_{CEX}	$V_{CE}=30\text{V}, V_{EB(off)}=3\text{V}$			0.05	μA	
Emitter cut-off current	I_{EBO}	$V_{EB}=5\text{V}, I_C=0$			0.1	μA	
DC current gain	h_{FE1}	$V_{CE}=1\text{V}, I_C=10\text{mA}$	100		400		
	h_{FE2}	$V_{CE}=1\text{V}, I_C=50\text{mA}$	60				
	h_{FE3}	$V_{CE}=1\text{V}, I_C=100\text{mA}$	30				
Collector-emitter saturation voltage	$V_{CE(sat)}$	$I_C=50\text{mA}, I_B=5\text{mA}$			0.3	V	
Base-emitter saturation voltage	$V_{BE(sat)}$	$I_C=50\text{mA}, I_B=5\text{mA}$			0.95	V	
Transition frequency	f_T	$V_{CE}=20\text{V}, I_C=10\text{mA}, f=100\text{MHz}$	300			MHz	
Delay Time	t_d	$V_{CC}=3\text{V}, V_{BE}=0.5\text{V},$ $I_C=10\text{mA}, I_{B1}=1\text{mA}$			35	ns	
Rise Time	t_r				35	ns	
Storage Time	t_s		$V_{CC}=3\text{V}, I_C=10\text{mA}$			200	ns
Fall Time	t_f		$I_{B1}=I_{B2}=1\text{mA}$			50	ns

CLASSIFICATION OF h_{FE1}

Rank	O	Y	G
Range	100-200	200-300	300-400

Typical Characteristics

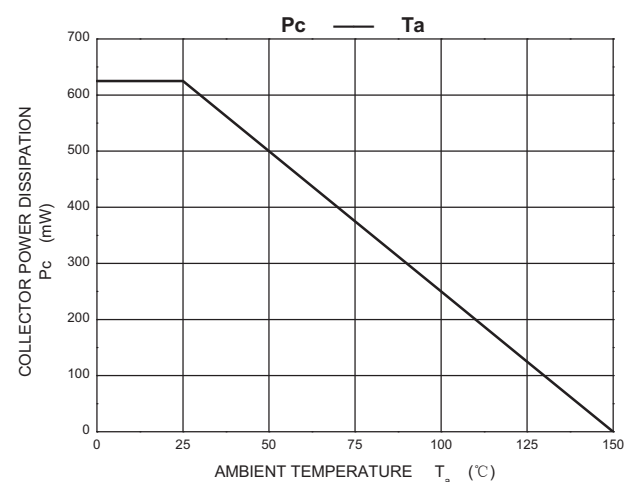
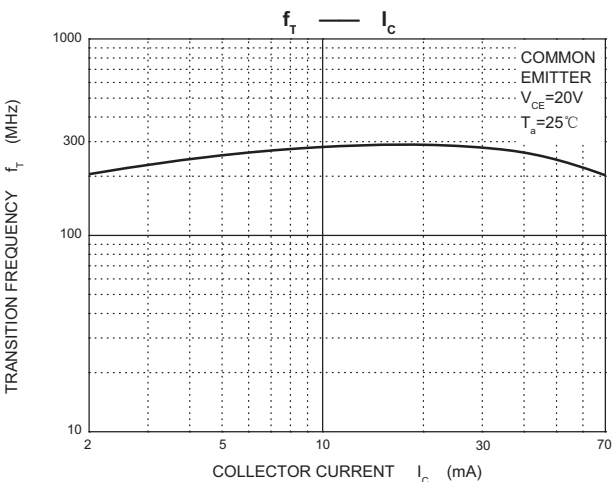
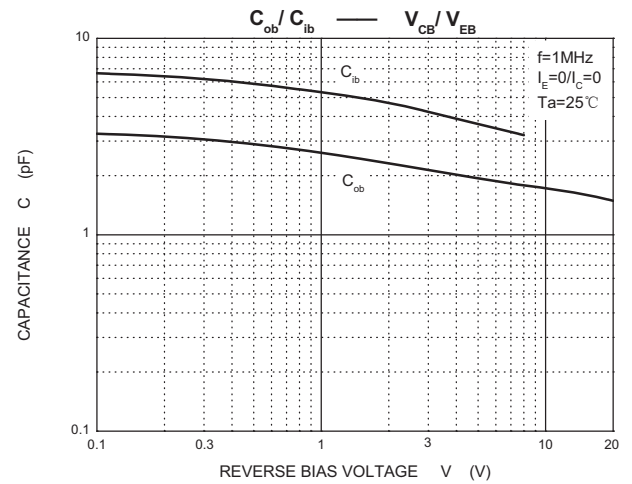
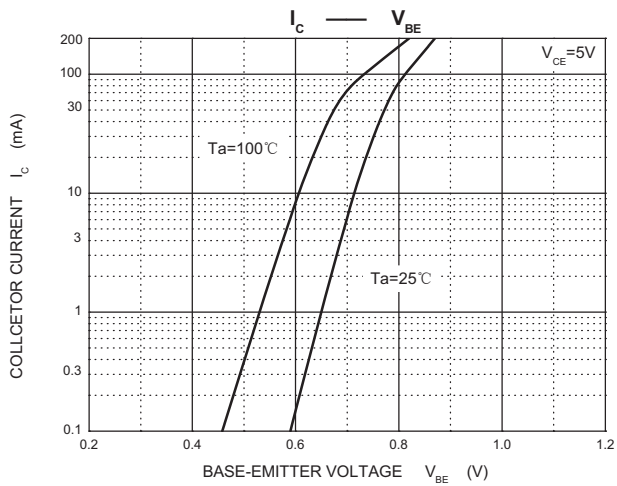
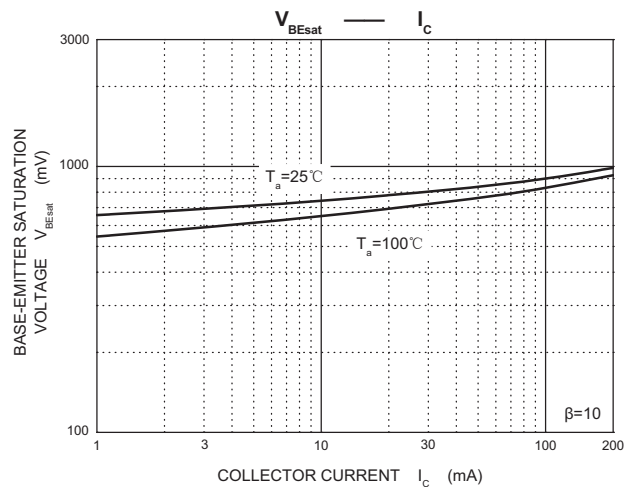
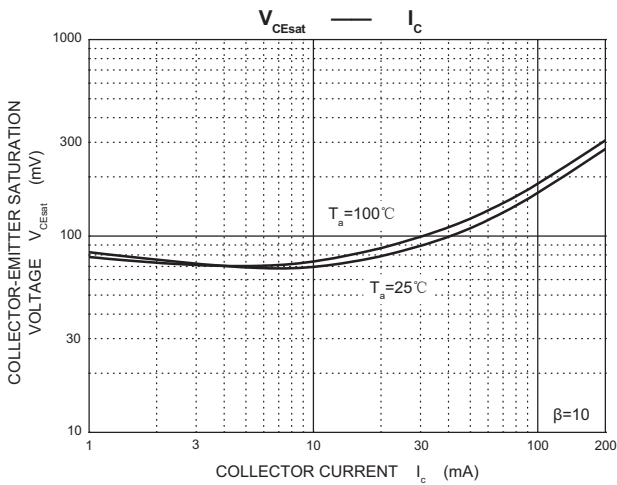
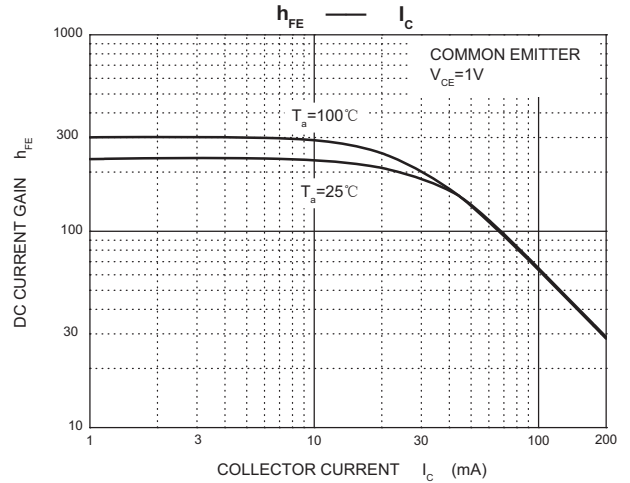
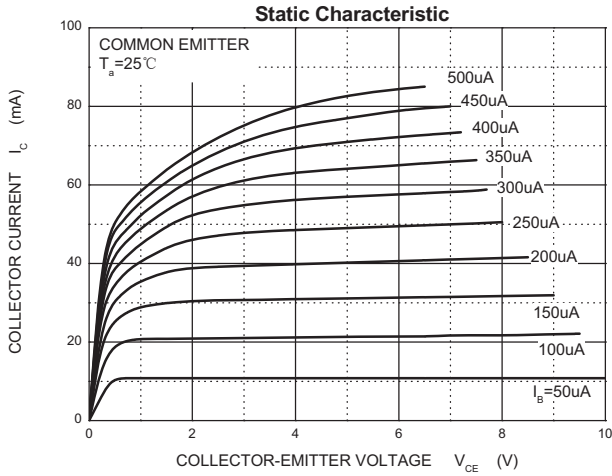

TO-92 Package Outline Dimensions

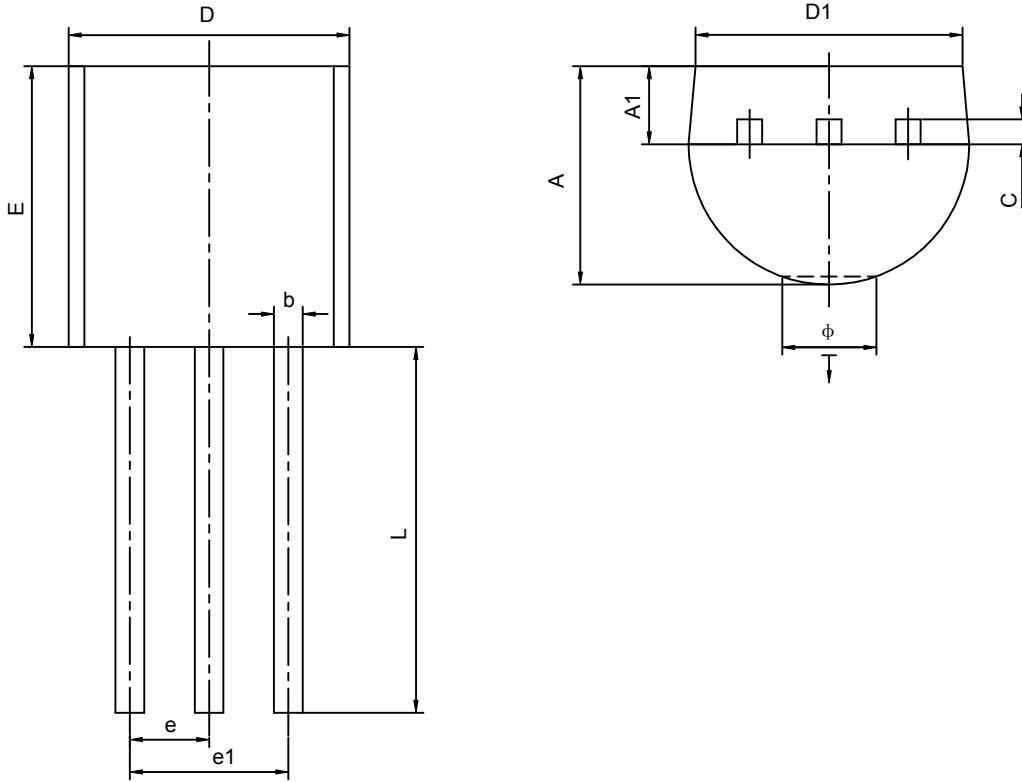

Symbol	Dimensions In Millimeters		Dimensions In Inches	
	Min	Max	Min	Max
A	3.300	3.700	0.130	0.146
A1	1.100	1.400	0.043	0.055
b	0.380	0.550	0.015	0.022
c	0.360	0.510	0.014	0.020
D	4.400	4.700	0.173	0.185
D1	3.430		0.135	
E	4.300	4.700	0.169	0.185
e	1.270TYP		0.050TYP	
e1	2.440	2.640	0.096	0.104
L	14.100	14.500	0.555	0.571
Ö		1.600		0.063
↓	0.000	0.380	0.000	0.015

TO-92 Tape and Reel

TO-92 PACKAGE TAPEING DIMENSION

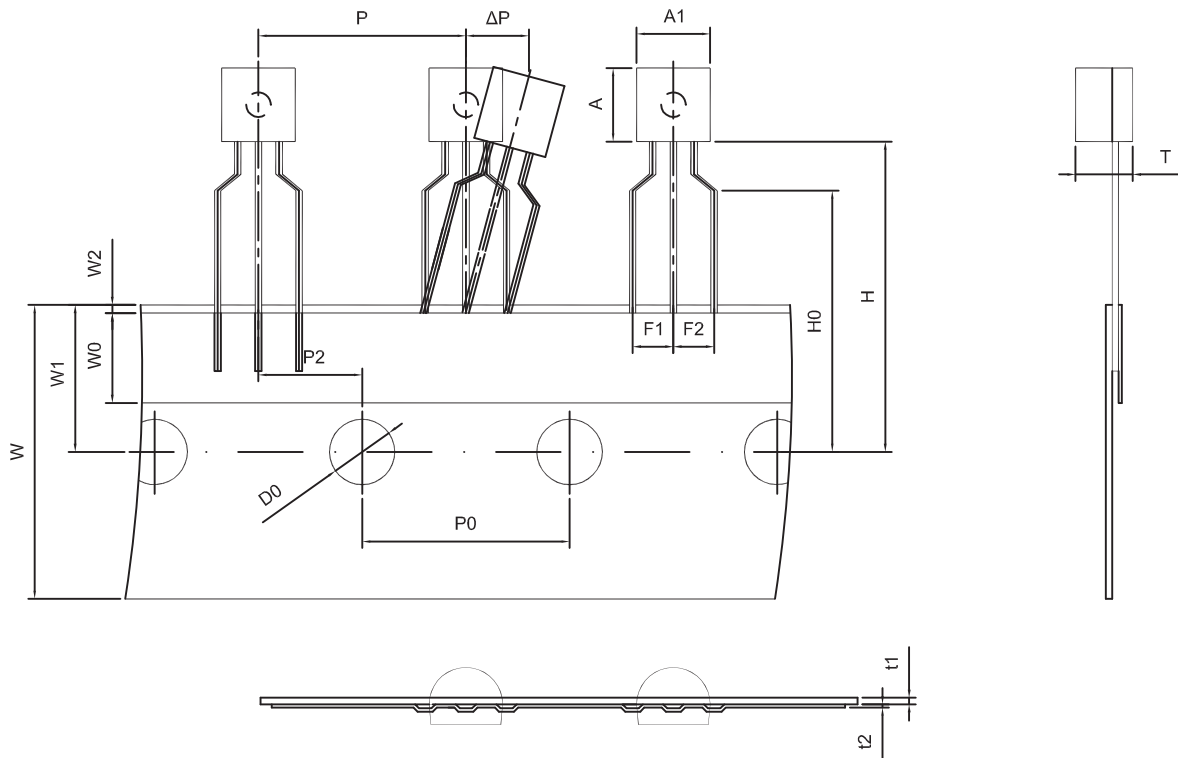

Dimiensions are in millimeter								
A1	A	T	P	P0	P2	F1	F2	W
4.5	4.5	3.5	12.7	12.7	6.35	2.5	2.5	18.0
W0	W1	W2	H	H0	D0	t1	t2	ΔP
6.0	9.0	1.0 MAX.	19.0	16.0	4.0	0.4	0.2	0

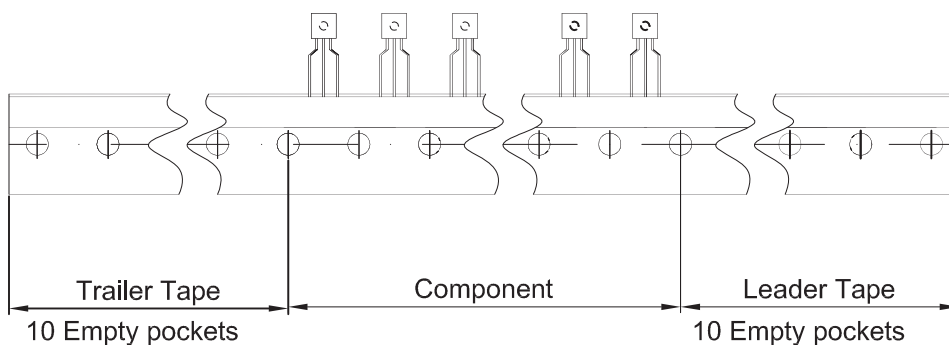

Package	Box	Box Size(mm)	Carton	Carton Size(mm)
TO-92	2000 pcs	333×162×43	20,000 pcs	350×340×250